

Sensor-to-Computer Interface Modules

FEATURES

Answer MAN Junior:

- Small size—only 1.5" × 0.875" 28-pin DIP package
- Low power—less than 30 mW at 5 V
- Operates on a wide power-supply input-voltage range
- Use for networked remote data acquisition and control
- Use for stand-alone or networked sensor-to-computer interface
- Direct input frequency measurement
- PWM output: 2 Hz to 3.5 kHz, 5–95% duty cycle
- 300 bps to 57.6 kbps serial communications
- 8 bidirectional, bit-programmable, high-current I/O lines: 25-mA sink per pin, 20-mA source per pin
- 4-channel 8-bit ADC
- Expandable to include 12-bit ADC/DAC
- Reads Dallas Semiconductor Touch Memory serial numbers
- 4 × 20 LCD control (see Addendum)
- 4 × 6 keypad scanning (see Addendum)
- High-performance built-in functions: Analog data averaging, V_{peak} and V_{min} recording, frequency measurement, totalization, high/low limit flags
- User-settable high/low ADC limits with autoactivated output flags
- Simple ASCII command set, requires no programming
- 16-character ID allows hundreds of modules per network
- Sturdy enclosed construction seals out harsh environment
- Industrial temperature range available

Answer MAN Senior also offers:

- 2.25" × 0.875" 28-pin DIP package
- Low power—less than 50 mW at 5 V
- RS-232A, RS-422, and RS-485 internal onboard level shifters
- 2-channel 12-bit ADC
- 1- or 2-channel 12-bit DAC

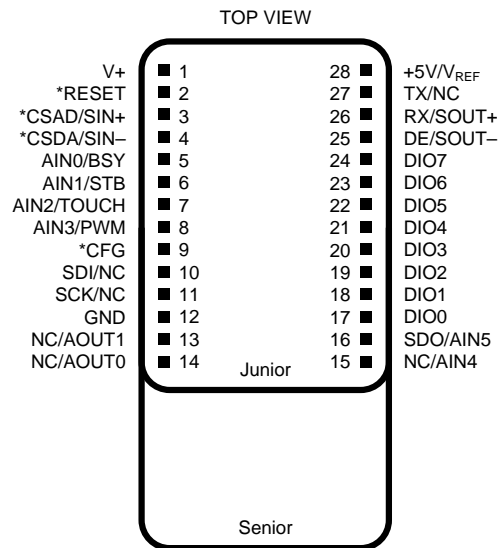

DESCRIPTION

The Answer MAN (Multidrop Acquisition Network) module is a low-cost network-based, data acquisition and control module. It is most frequently used as a practical multipurpose interface between sensors and the computer. Answer MAN's small 0.8-cubic-inch enclosed module and standard 28-pin DIP packaging allow it to be incorporated directly with a sensor or control device to add an analog-to-serial data interface or to otherwise supplement the control intelligence at the sensor end of things.

While we could have called it the XYZ-5000 DAS Module, we wanted to exemplify what it does rather than how we think you'll use it. Answer MAN is just that—it waits with your sensor or control device for commands uniquely addressed to it. These commands either "Set" Answer MAN's outputs or "Query" the user about Answer MAN's inputs. Questions like "What's the voltage on Input 3, ...the switch setting on bit 4, ...the temperature, ...the frequency"—Answer MAN simply answers directly or via a network.

Similar commands tell Answer MAN to set its PWM output to a particular frequency, its DAC output to 3.42 V, or its digital outputs to a particular logic state.



Answer MAN is a DIP module which incorporates digital inputs and outputs, analog inputs and outputs, power input regulation, communication line drivers, and powerful coordination software. Connected together on a network, Answer MANs provide an efficient and cost-effective, distributed closed-loop control environment.

Answer MANs can be used independently (RS-422, RS-232) or networked (RS-485) together. Depending on the driver chips and network connection technology, two to thousands of Answer MANs can be used together (Answer MAN's 16-character ID allows virtually an unlimited number). With typical RS-485 drivers, 32–64 modules can be connected on a single 4000' RS-485 twisted pair without a network repeater.

Answer MAN comes in two varieties: Junior and Senior. Answer MAN Jr. is packaged in a 1.5" × 0.875" 28-pin DIP package. It has input power regulation, 8 bits of bit-programmable parallel I/O, four 8-bit ADC inputs, TTL serial communications lines with data direction control, and an expansion bus for off-module connection to a 2-channel 12-bit ADC and two single-channel 12-bit DACs. Some of the digital and 8-bit ADC lines are also dual-function, depending on module configuration.

Answer MAN Sr. is everything in a single package. Primarily intended to allow OEMs the option of a pick-and-choose full-up configuration, Senior is a 28-pin DIP package which is stretched to 2.25" × 0.875". Senior contains the same electronic core as Junior plus the 2-channel 12-bit ADC, two 12-bit DACs, and combined function RS-422, RS-485, and RS-232A communication line drivers. While Junior and Senior are both 28-pin devices, their pinouts are somewhat different. They are not directly interchangeable for all functions.

Answer MAN Jr. and Sr. need no programming to function. Initial setup and configuration is done through a serial terminal or PC terminal emulator program and simple configuration commands. These selections, along with the user-designated module ID reference name and selected communication rate are stored in Answer MAN's configuration EEPROM. The module can be reconfigured at any time.

Reading digital and analog inputs or setting digital or analog outputs is accomplished using simple ASCII command statements. Setting or reading Answer MAN uses logical commands like Set (S) and Query (Q). Sending an ASCII string to query Answer MAN's analog inputs uses the logical command QA. Setting Answer MAN's PWM output (SP *tp hp*) is as simple as declaring a total period length and the portion of it to be a logic high. At 57.6 kbps, most commands take only about 4–8 ms.

Answer MAN also has the ability to read Dallas Semiconductor iButton (Touch Memory) device serial numbers. With its iButton serial-number recognition, Answer MAN can perform as the core of cost-effective security-access and personnel-tracking applications.

Finally, both Answer MAN devices contain onboard power regulation. A typical network solution might use a 4-wire cable, rather than just a 2-wire twisted pair, with two wires supplying RS-485 data while the other pair supplies +12 V and ground (9–12 V is recommended). When Answer MAN is powered from 9–12 V, the output of its onboard regulator (approx. 100 mA) is available to power externally connected devices. Alternatively, Answer MAN Jr. can be powered with only 5 V.

ABSOLUTE MAXIMUM RATINGS

Supply Voltage	+16.0 V
Digital Input Voltage	–0.5 V to +6.5 V
Analog Input Voltage	–0.5 V to +5.5 V
Storage Temperature	–25°C to +100°C
Lead Temperature	260°C
Operating Temperature	0°C to +70°C
	(–40°C to +85°C available by special order)

Stresses above those listed under "Absolute Maximum Ratings" may cause permanent damage to the device. This is a stress rating only and functional operation of the device at those or any other conditions above those indicated in the operation listings of this specification is not implied. Exposure to maximum rating conditions for extended periods may affect device reliability.

PIN DESCRIPTIONS

Both Answer MAN Junior and Answer MAN Senior are 28-pin DIPs with 0.6" spacing.

Pins with a dual designations indicate either different functions for Answer MAN Junior and Answer MAN Senior, or default and optional functions for both modules.

Pin	Signal	Description	Pin	Signal	Description
1	V+	Answer MAN power-supply input. V+ is nominally 9–12 V. If pin 1 is open, Answer MAN can be +5-V-powered directly to pin 28.	12	GND	Combined digital and analog ground
2	*RESET	When grounded, *RESET provides a master clear of the system; all outputs are cleared	13	NC/AOUT1	AMJr: No connection AMSr: Analog output, channel 1, 12 bit, 0–5 V
3	*CSAD/SIN+	AMJr: External serial ADC chip-select line AMSr: RS-422/-485 noninverted serial input line (receive pair/rec-xmit pair/receive)	14	NC/AOUT0	AMJr: No connection AMSr: Analog output, channel 0, 12 bit, 0–5 V
4	*CSDA/SIN–	AMJr: External serial DAC chip-select line AMSr: RS-422/-485/-232A inverted serial input line (receive pair/rec-xmit pair)	15	NC/AIN4	AMJr: No connection AMSr: Analog input, channel 4, 12 bit, 0–5 V
5	AIN0/BSY	Def.: Analog input, channel 0, 8 bit, 0–5 V Opt.: Parallel printer function busy input	16	SDO/AIN5	AMJr: Expansion bus serial data output line—for connection to external serial peripheral chips AMSr: Analog input, channel 5, 12 bit, 0–5 V
6	AIN1/STB	Def.: Analog input, channel 1, 8 bit, 0–5 V Opt.: Parallel printer function strobe output	17–24	DIO0–DIO7	Digital input/output port, TTL-level; each bit is bidirectional and bit-programmable; DIO0 is the frequency input
7	AIN2/TOUCH	Def.: Analog input, channel 2, 8 bit, 0–5 V Opt.: Touch Memory probe input	25	DE/SOUT–	AMJr: Expansion bus serial driver enable control AMSr: RS-422/-485/-232A inverted serial output line (transmit pair/rec-xmit pair)
8	AIN3/PWM	Def.: Analog input, channel 3, 8 bit, 0–5 V Opt.: PWM output	26	RX/SOUT+	AMJr: Inverted TTL-level serial input AMSr: RS-422/-485 noninverted serial output line (transmit pair/rec-xmit pair/transmit)
9	*CFG	Configuration input; ground to enter configuration mode	27	TX/NC	AMJr: Inverted TTL-level serial output AMSr: Not used
10	SDI/NC	AMJr: Expansion bus serial data input line—for connection to external serial peripheral chips AMSr: Not used	28	+5V/V _{REF}	This is the +5-V internal ADC and DAC voltage reference (nominally 5.0 V). This output may be used to power minimal external circuitry or sensors. Answer MAN Jr. may be powered by +5 V only through this pin, provided pin 1 is left unconnected.
11	SCK/NC	AMJr: Expansion bus serial clock line—for connection to external serial peripheral chips AMSr: Not used			



MECHANICAL SPECIFICATIONS

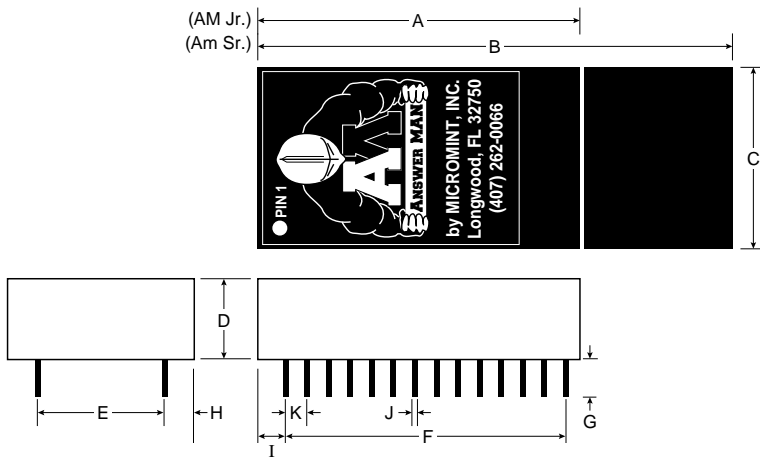

Dim	Inches		Millimeters	
	min	max	min	max
A	1.490	1.510	37.85	38.35
B	2.190	2.210	55.62	56.12
C	0.850	0.870	21.60	22.10
D	0.364	0.384	9.25	9.75
E	0.590	0.610	14.98	15.49
F	1.290	1.310	32.76	33.26
G	0.240	0.300	6.09	7.62
H	0.075	0.185	1.90	4.69
I	0.080	0.215	2.03	5.46
J	0.020	0.030	0.51	0.76
K	0.095	0.105	2.41	2.66

DC Electrical Characteristics

Operating Temperature $T_a = 0^\circ\text{C}$ to 70°C
 Operating Voltage $V_{\text{RAW}} = 12\text{ V}$, $\text{GND} = 0\text{ V}$

Characteristic	Min	Typ	Max	Units	Condition
Supply Voltage (V_{RAW})	9	12	16	V	AM Jr. AM Sr., RS-422/485
Supply Current (I_{CC})		2 4		mA mA	
Input Low Voltage (V_{il})	-0.5		0.9	V	$I_{\text{ol}} = 1.6\text{ mA}$ $I_{\text{ol}} = -10\text{ }\mu\text{A}$ $I_{\text{ol}} = -400\text{ }\mu\text{A}$
Input High Voltage (V_{ih})	1.9		5.5	V	
Output Low Voltage (V_{ol})		0.45		V	
Output High Voltage (V_{oh})	4.5			V	
Printer Port-mode Strobe	2.4		3	μs	

Communication Line DC Electrical Characteristics

Characteristic	Min	Typ	Max	Units	Condition
Differential Driver Output Voltage			5.0	V	Unloaded See note 1
RS-422	2.0		5.0	V	$R = 50\text{ }\Omega$
RS-485	1.5		5.0	V	$R = 27\text{ }\Omega$
Maximum Receiver Input Voltage	± 14			V	
ESD Protection		2000		V	

D/A Converter Characteristics					
Answer MAN Sr. only					
Characteristic	Min	Typ	Max	Units	Condition
Resolution	12			bit	V_{REF} is V_{CC} measured to ground
Full-Scale Error		$\frac{1}{2}$		bit	
Offset Error			± 8	bit	
Voltage Reference		5.0	V_{REF}	V	
Analog Output Impedance		150	300	Ω	

A/D Converter Characteristics					
Answer MAN Jr./Sr.					
Characteristic	Min	Typ	Max	Units	Condition
Resolution	8			bit	V_{REF} is V_{CC}
Linearity Error		$\pm \frac{1}{2}$		bit	
Offset and Gain Error		± 1		bit	
Voltage Reference	4.5	5.0	5.5	V	
Analog Input Range		-0.5 to $V_{REF}+0.5$		V	
Analog Input Impedance		10k		Ω	
Answer MAN Sr.					
Characteristic	Min	Typical	Max	Units	Condition
Resolution	12			bit	V_{REF} is V_{CC} See note 2
Linearity Error		$\pm \frac{3}{4}$		bit	
Offset and Gain Error		± 2		bit	
Voltage Reference	4.5	5.0	5.5	V	
Analog Input Range		-0.5 to $V_{REF}+0.5$		V	
Analog Input Impedance		250k		Ω	

Note 1: RS-232A is characterized as a ± 5 -V bipolar signal (as opposed to RS-232C at ± 12 V). Drivers and receivers are actually RS-422 and the serial interface is an RS-423 connection (single ended to differential). Answerman RS-232A voltage output is 0-5v only.

Note 2: Two diodes are tied to each analog input which will conduct when the input voltage is one drop below V_{SS} or one drop above V_{REF}/V_{CC} . To achieve absolute 005-V input range requires V_{REF} to be greater than 4.950 V.

Note 3: Answer MAN Jr. uses an expansion bus for connection to external ADCs and DACs. The default devices supported are the LTC1298 and LTC1257. Answer MAN Jr. can be custom programmed to support other devices for a programming fee.



1.0 JUNIOR AND SENIOR: UNDERSTANDING THE DIFFERENCE

It is important to understand the difference between Answer MAN Jr. and Sr. to properly select the appropriate configuration for your application.

Figure 1.1 shows a basic Answer MAN Jr. with no external expansion. It supports eight digital I/O lines, four 8-bit analog inputs, and communicates using TTL serial. It also has several interface lines that allow the addition of serial drivers and 12-bit analog I/O.

Answer MAN Sr. includes everything that Answer Jr. does plus adds RS-232A, RS-422, or RS-485 serial interfacing; two 12-bit analog inputs; and two 12-bit analog outputs (see Figure 1.2).

It's possible to create an Answer MAN Sr. using an Answer MAN Jr. and some external circuitry. Figure 1.3 shows what circuitry is necessary to add the extra functions. The only differences between an Answer MAN Sr. and the circuit shown in Figure 1.3 are Answer Sr. uses RS-232A (0–5 V) while the figure uses a MAX232 (± 8 V), and Answer MAN Sr. supports RS-422 and RS-485 while the figure shows just RS-485 interfacing.

Both modules also support the remaining feature set: PWM output, frequency input, totalizer input, and printer output. Note that not all features are available simultaneously. See Section 7 for more details.

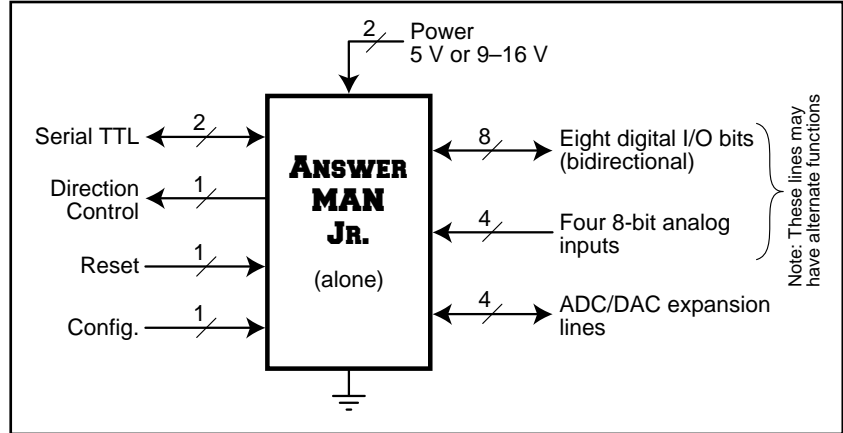

Figure 1.1: Answer MAN Jr. with no external circuitry.

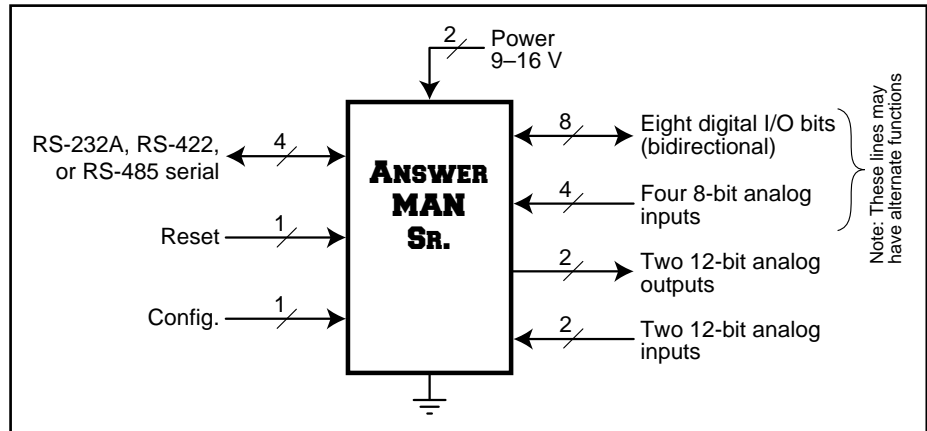

Figure 1.2: Answer MAN Sr. with complete built-in support.

The Answer MAN Development Board may also be used to “upgrade” an Answer MAN Jr. to an Answer MAN Sr. See Section 16 for more details.

2.0 QUICK START

You probably want to hook up the Answer MAN and try it out without having to read this whole datasheet. Use the following steps to connect and configure the Answer MAN for basic operation. Be sure to thoroughly read the remaining sections before trying to use any of the features not described here.

1. Connect a 9–12-V power supply to pins 1 (V+) and 12 (GND) of the Answer MAN (or the +V and GND terminals on the Answer MAN Development board), but don't turn it on yet.
2. Connect a serial terminal or a PC running communications software to pins 4, 25, and 12 of the Answer MAN (Sin-, Sout-, and GND) as shown in Figure 3.1.

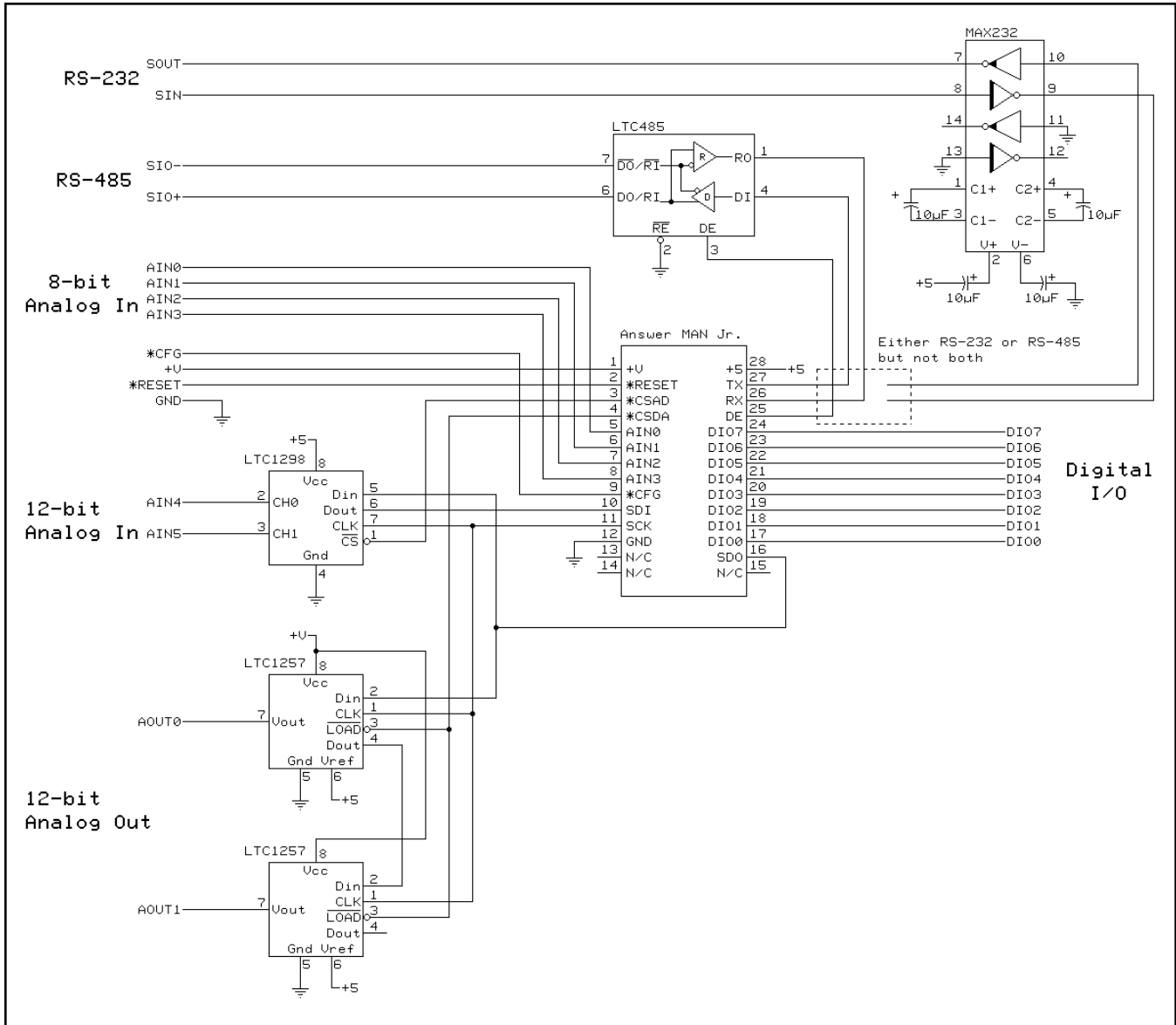

Figure 1.3: Answer MAN Jr. with external circuitry added.

3. Set the terminal or comm software to operate at 9600 bps, 8N1.
4. Ground configuration pin 9 of the Answer MAN (or install a jumper on JP4 of the Development Board) to select configuration mode, and turn the power on.
5. A sign-on banner should appear on the terminal display.
6. Remove the connection from pin 9 (or the jumper from JP4) and allow the pin to float.
7. Use the commands described in Sections 5 and 6 to exercise the Answer MAN. Initially, try out the QA, QI, SO, and SD commands. Save the others for later.
8. When you're satisfied everything is working, continue reading to find out how to configure and use all of the module's features.



3.0 ANSWER MAN SETUP

Answer MAN was designed to be easy to set up and configure. The basic steps involved in setting up a module include:

- Connect the module to a terminal or PC using RS-232.
- Power up the module in configuration mode.
- Select the module configuration options using the CO command.
- Manually try out commands by typing them on the command line.
- Power down the module and install it in the target application.
- The next time the module is powered up, it will be in operational mode, fully configured and functional.

3.1 COMMUNICATION OPTIONS

Answer MAN offers several methods of communication, allowing maximum flexibility in setting up the target application. The options include RS-232A, RS-422, and RS-485.

3.1.1 RS-232A

When people talk about RS-232, they usually mean RS-232C. RS-232C uses high, bipolar voltages (typically ± 12 V) to send serial data. RS-232A is a low-voltage version of the same signal. RS-232C and RS-232A can often coexist since interface chips used in both can usually handle a wide range of voltages.

By connecting the SIN- and SOUT- lines on the Answer MAN to a normal RS-232C port, the module can be used by most any device with a serial port. The receiver on the Answer MAN can handle the high voltages used by RS-232C and most RS-232C receivers have low enough switching thresholds that they easily detect the 0–5-V swings of the Answer MAN's transmitter.

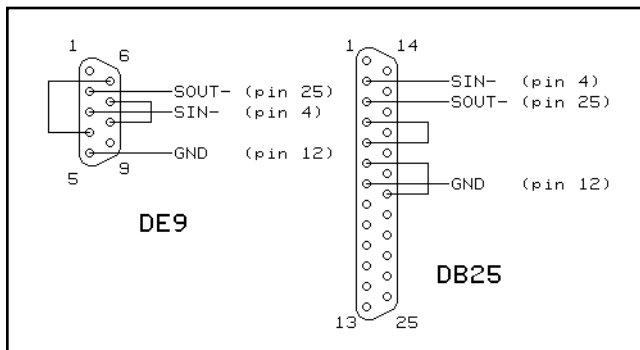

Figure 3.1: Answer MAN Sr. connections to an RS-232 interface.

Figure 3.1 shows how to connect the Answer MAN Sr. to an RS-232C device.

3.1.2 RS-422

The primary serial interface on the Answer MAN Sr. is a true RS-422 interface. RS-422 uses differential signaling to achieve reliable communication distances of up to 4000 feet (versus 50 feet with RS-232C). Similar to RS-232, RS-422 allows you to connect just two devices together. A 100- Ω terminating resistor should be placed across each pair at the receiving end of any long cable runs. It is up to the user to provide this termination.

Figure 3.2 shows how to connect the Answer MAN Sr. to an RS-422 device.

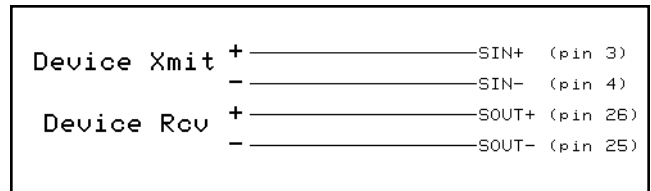

Figure 3.2: Answer MAN connections to an RS-422 interface.

3.1.3 RS-485

RS-485 is very similar to RS-422 but uses just one twisted pair of wires. Although this arrangement allows only one device to transmit at a time, it also allows up to 32 devices to be connected to the same wire pair. Multiple Answer MAN modules may be connected to a master to form a network. When more than 32 devices are required, Micromint RS-485 repeaters may be used to break the 32-device barrier.

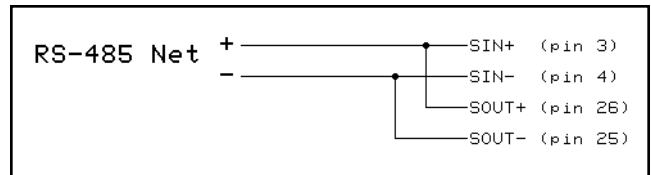

Figure 3.3: Answer MAN Sr. connections to an RS-485 interface.

A 100- Ω terminating resistor should be placed across the wire pair at each end of the wire. There should not be more than two such resistors on any network.

To improve reliability, it's also a good idea to include a 1-k Ω pull-up resistor on the positive side and a 1-k Ω pull-down resistor on the negative side of the wire pair.

Only one set of pull-up/pull-down resistors should be on any network.

It is up to the user to provide all terminating and pull-up/pull-down resistors.

RS-485 is used when the module is in operational mode. Figure 3.3 shows how to connect the Answer MAN to an RS-485 network.

3.2 CONFIGURATION/OPERATIONAL MODES

Answer MAN supports two functional modes: configuration and operational. Configuration mode is usually used to configure the module since it supports a user-friendly command-line interface. Operational mode is usually used when the module is placed into the target application since it supports a more concise and rigid packet format for commands. The command format for both modes is covered in more detail in Section 4.

Under all circumstances, when Answer MAN's *CFG pin (pin 9) is grounded when the module is reset or

powered up, the module enters configuration mode and assumes a baud rate of 9600 bps and an RS-232A or RS-422 connection. This behavior allows you to access the module using predictable conditions regardless of the contents of the module's EEPROM.

When the *CFG pin is floating at reset or powerup, Answer MAN reads the configuration word from EEPROM to determine what mode to come up in. (See the CO command in Section 6 for more details on the configuration word.) If bit 12 is clear, the module comes up in operational mode. If bit 12 is set, the module comes up in configuration mode. In either case, the serial port baud rate is set for whatever rate was selected using the CB command. If no rate has been set, a default of 9600 bps is used.

The type of serial port interface is determined by the module's mode. When the Answer MAN is in configuration mode, it uses the RS-232A or RS-422 interface. If the module is in operational mode, the RS-485 interface is used.

4.0 COMMAND FORMAT

Answer MAN supports two different serial modes: configuration and operational. Configuration mode is entered by making sure pin 9 is grounded (or a jumper is installed in JP4 on the Answer MAN Development Board) when power is applied to the module. Operational mode is entered when pin 9 (or JP4) is left open and unconnected.

Configuration mode always defaults to a serial port baud rate of 9600 bps (8N1) (when *CFG is grounded). Other baud rates may be set for operational mode.

When in configuration mode, the module's name along with a greater-than sign (>) is displayed as a command prompt. The user may type any command found in Sections 5 and 6 at the command prompt and see the results immediately. Replies are sent back formatted as described in Section 6 and are followed by a carriage-return/line-feed pair.

In operational mode, commands must be sent to the Answer MAN in a rigid packet format and followed by a carriage return. The basic packet format is as follows:

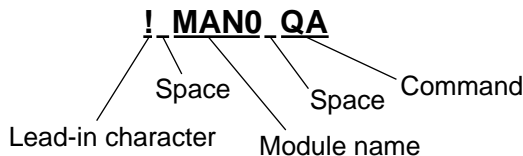

To increase reliability, a checksum may be included with the packet. The format of the checksummed packet is as follows:

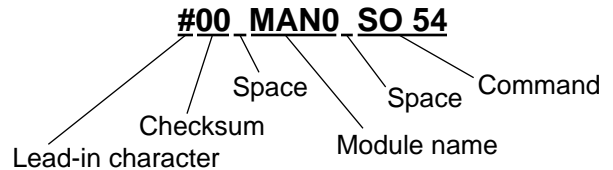

All operational mode replies use a "\$" lead-in character whether they include a checksum or not. Inclusion of a checksum is based on whether the command that triggered the reply contained one. The two reply formats are as follows:

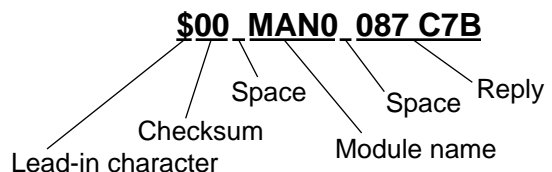
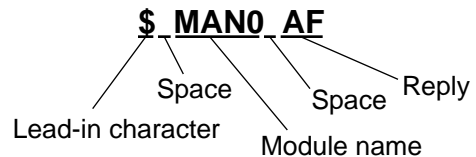



Operational mode replies are followed by a line-feed/carriage-return pair.

In operational mode, commands may be typed by the user or may be sent over the network by a computer. Obviously, commands that include a checksum are much more difficult to type by hand. Commands are not echoed, and those that don't generate an explicit reply are not acknowledged.

4.1 PACKET CHECKSUMS

The following steps should be taken to generate a packet with a checksum:

- Construct the whole packet and include "00" where the checksum will eventually be placed.
- Starting with the leading "#" character, add the ASCII value of every character in the packet up to but not including the trailing carriage return. Throw away any portion of the result beyond the low-order 8 bits (i.e., modulo 256).
- Take the two's complement of the result.
- Convert the final result to two ASCII hex digits and insert it in the proper place in the packet.

To verify the checksum of a received packet, use the following steps:

- Read the two ASCII hex digits of the received checksum and convert them to an 8-bit binary value.
- Replace the checksum in the received packet with "00".
- Starting with the leading "\$" character, add the ASCII value of every character in the packet up to but not including the trailing carriage return. Also, add in the received checksum value. Throw away any portion of the result beyond the low-order 8 bits.
- The final result should be 00.

4.2 TIMING

Command timing is dependent on network and module activity, so it's difficult to cite specific values. However, in general the following is true:

Minimum time between consecutive Set commands: 500 µs (typical)

Maximum time between end of query command and start of reply packet: 1 ms

5.0 COMMAND SET SUMMARY

A= <i>string</i>	Set network address to <i>string</i> (16 characters max). The address is case sensitive .	QD	Query DAC (analog outputs) settings (AOUT0–AOUT1).
CB <i>n</i>	Configure operating mode baud rate. Valid values for <i>n</i> are 3 (300), 12 (1200), 24 (2400), 96 (9600), 19 (19.2k), or 57 (57.6k).	QE	Query everything. Returns the status of the digital outputs, digital inputs, analog outputs, and analog inputs. Module configuration, frequency input, and Touch Memory must be queried individually.
CD <i>n</i>	Configure delay between receipt of a query and the module's reply. The hexadecimal value indicates the delay in milliseconds (00–FE).	QF	Read frequency on pin 17 (DIO0). Input range: 2 Hz–2 kHz.
CO <i>n</i>	Configure module options. See the CO command details for a discussion of valid values.	QI	Query digital input port (DIO0–7).
QA	Read analog inputs (AIN0–AIN5).	QM	Read 12-bit analog inputs and return the current, average, maximum, and minimum values of the last 8 readings. The min and max values are reset after being read if the module is configured to do so. Otherwise, they must be cleared manually using the RM command.
QB	Read current I/O port bit directions.	QO	Query digital output port setting (DIO0–7).
QC	Query the current module configuration. If the value returned is different from that set with the CO command, it is because an invalid combination of features was requested. See Section 7 for more details.	QP	Query printer status. Returns 00 if no error has occurred or FF if there has been an error communicating with the printer.

QS	Query the serial number of the last Touch Memory device read. Returns all zeros if nothing new has been read.	SD <i>n0 n1</i>	Set DACs (analog outputs).
QT	Query the total number of falling edges that have come in on pin 17 (DIO0) since the last time the totalizer was cleared.	SL <i>ch lo hi</i>	Set the high/low threshold limits for analog input channel <i>ch</i> .
RE	Reset (clear) EEPROM contents and re-start the module.	SLD <i>ch lo hi</i>	Set default threshold values. The values are stored in EEPROM and are used at powerup if limit checking has been configured.
RM	Reset analog input min/max storage.	SO <i>n</i>	Set digital outputs (DIO0–7).
RT	Reset the totalizer count.	SP <i>tp hp</i>	Set PWM output on pin 8 (AIN3/PWM). <i>tp</i> is total period count and <i>hp</i> is the count representing the logic-high-level portion of it. <i>tp</i> must be greater than <i>hp</i> and counts are 4-digit hex values. Each count represents 8.94 μ s. Approximate range is 2 Hz–3.5 kHz, 5–95% duty cycle.
S= <i>string</i>	Print appended text string to parallel printer. The firmware incorporates a 32-character buffer for the incoming message, but it is limited by the speed of the printer to empty it. You should avoid sending large numbers of long messages unless you provide sufficient time between transmissions.	SPD <i>tp hp</i>	Set default PWM values. The values are stored in EEPROM and are used at powerup if the PWM output has been configured.
SB <i>n</i>	Set the I/O port bit directions. A 1 in a bit position sets the corresponding I/O bit to be an input. A 0 sets the bit to be an output.	ST <i>period</i>	Set the totalizer debounce period.
SBD <i>n</i>	Set the default I/O port bit directions. The value is stored in EEPROM and is used at powerup.		

6.0 COMMAND SET DETAILS

Answer MAN supports four basic commands: configuration, query, clear, and set. Only the query commands generate a response from the module. When the module is in configuration mode, all commands may be directly typed in from the console. When in operational mode, all commands must begin with a proper packet header, checksum, and module address.

A Set module network address

When in operational mode, Answer MAN responds to only those commands addressed to it. The module may have an address consisting of up to 16 characters. If no address is set, the default is MAN0. Note that the address is case sensitive. In configuration mode, Answer MAN displays the current module name as the command prompt.

Syntax: A=*string*

where: *string* = any string consisting only of letters and numbers up to 16 characters long

Hardware: Answer MAN Jr. or Sr.

Example: A=Module1
Set the Answer MAN's network address to Module1.

CB Configure operational-mode baud rate

Answer MAN always communicates at 9600 bps in configuration mode when the *CFG pin is held low. However it may be set up to run at one of six rates in either configuration or operation mode when the *CFG pin is held high. The new baud rate is saved in EEPROM and takes effect the next time the module is started in operational mode.

Syntax: CB *n*



where: $n = 3$ (300), 12 (1200), 24 (2400),
96 (9600), 19 (19.2k), or
57 (57.6k)

Hardware: Answer MAN Jr. or Sr.

Example: CB 19
Set Answer MAN to operate at 19.2 kbps.

CD Configure reply delay

Answer MAN is very quick to reply to query commands sent by the host. However, sometimes the replies may come so quickly that the host isn't ready to receive them. It is possible to configure a delay of up to 254 ms between the receipt of a query command and Answer MAN's reply. The value is stored in EEPROM and remains in effect even when the module power is cycled. This command only works in configuration mode.

Syntax: CD n

where: $n =$ number of milliseconds of delay
(00–FE, in hexadecimal)

Hardware: Answer MAN Jr. or Sr.

Example: CD 38
Set Answer MAN to delay at least 56 ms between receiving a query and sending its reply.

CO Configure module options

While Answer MAN supports many kinds of I/O, only certain combinations may be used simultaneously. The

module must be configured for the desired I/O before it can be used.

Note that the module automatically disables certain options if an invalid combination is requested (see Section 7), and some options require additional hardware or only work with either Answer MAN Jr. or Answer MAN Sr. Use the QC command to view the current option settings. When the user enters fewer than four hex digits, leading zeros are assumed.

When a bit is set within the configuration word, it enables the option corresponding to that bit. Clear individual bits to disable options.

This command only works when the module is in configuration mode. See Figure 6.1 for more details.

Syntax: CO n

where: $n =$ option bitmap (in hexadecimal)
as follows:

- bit 0: enable 12-bit analog I/O
- bit 1: enable 8-bit analog inputs
- bit 2: enable PWM output
- bit 3: enable frequency input

- bit 4: enable printer output
- bit 5: clear analog min/max after query
- bit 6: enable 12-bit analog limit checking
- bit 7: enable 8-bit analog limit checking

- bit 8: enable Touch Memory reading
- bit 9: enable totalizer
- bit 10: reserved
- bit 11: reserved

- bit 12: force configuration mode on reset
- bit 13: enable LCD/keypad support

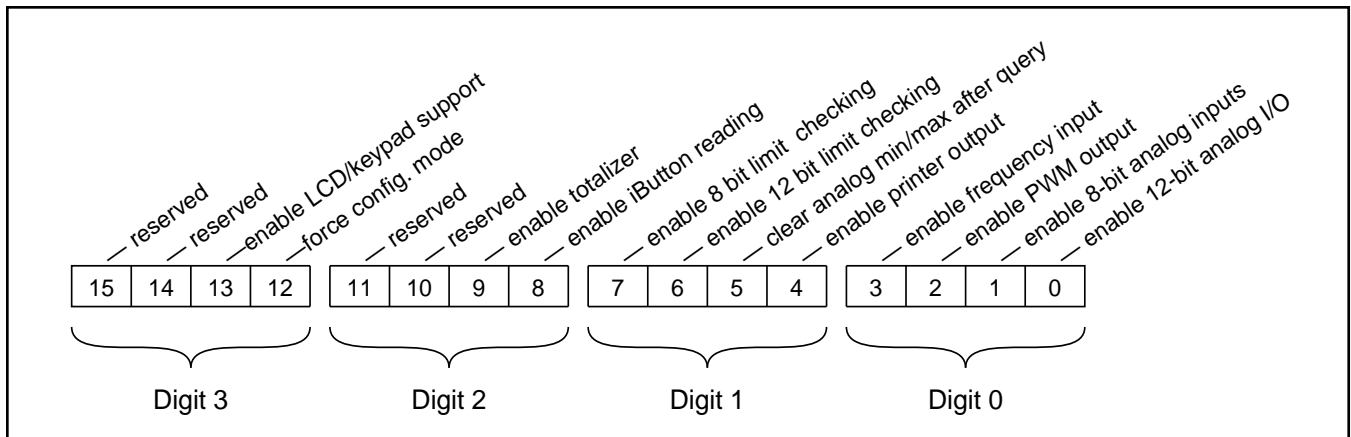

Figure 6.1: Answer MAN configuration word.

bit 14: reserved
bit 15: reserved

Hardware: depends on options enabled

Example: CO 0103
Enable the Touch Memory and 8- and 12-bit analog I/O options.

Syntax: QB
byte

where: byte= 2-digit hex value representing I/O port bit directions

Hardware: Answer MAN Jr. or Sr.

Example: QB (command)
B:05 (reply)
I/O port bits 0 and 2 are set for input while bits 1 and 3–7 are set for output.

QA Read analog inputs

Answer MAN Jr. supports four 8-bit analog inputs (AIN0–3). Additionally, Answer MAN Sr. supports two 12-bit analog inputs (AIN4–5). The readings are returned as two-digit hexadecimal values (8 bit) or three-digit hex values (12 bit) separated by spaces. Both kinds of analog inputs support just 0–5 V on their inputs. The 8-bit channels return values in the range of 00–FF and the 12-bit channels return 000–FFF.

Syntax: QA
n0 n1 (12-bit)
b0 b1 b2 b3 (8-bit)

where: n0, n1 = 3-digit, 12-bit readings
b0–b3 = 2-digit, 8-bit readings

Hardware: Answer MAN Jr. and Sr. for 8-bit inputs, Answer MAN Jr. with external ADC or Sr. for 12-bit inputs

Examples: QA (command)
A4:176 A5:934 (reply)
Answer MAN Sr. analog channel 0 has a voltage of 0.456 V applied to it, and channel 1 has a voltage of 2.876 V applied to it.

QA (command)
A0:23 A1:B7 A2:40 A3:03 (reply)
Answer MAN Jr. analog channels have voltages of 0.68 V, 3.57 V, 1.25 V, and 0.06 V applied to them.

QB Query the I/O port bit directions

Answer MAN's eight digital I/O lines may be configured for either input or output on a bit-by-bit basis. QB returns the current settings of the eight I/O bit directions (in hexadecimal). A 1 in a bit position indicates the corresponding I/O bit is set for input. A 0 indicates the bit is set for output.

QC Query the module configuration

While the Answer MAN supports many different kinds of I/O, only certain options may be used simultaneously. The network master may use the QC command to query the Answer MAN to find out what options it has enabled. See the CO command for a description of the format of the data returned.

Syntax: QC
word

where: word = 4-digit hex value representing module configuration

Hardware: Answer MAN Jr. or Sr.

Example: QC (command)
C:0021 (reply)
Answer MAN Sr. configured for 12-bit analog inputs and to clear the min/max storage after reading them.

QD Query DAC (analog output) settings

Answer MAN Sr. supports two 12-bit analog outputs (AOUT0–1). QD can be used to read back the current settings of them. The settings are returned as three-digit hexadecimal values separated by spaces and are in the range of 000–FFF.

Syntax: QD
n0 n1

where: n0, n1 = 3-digit, 12-bit settings

Hardware: Answer MAN Jr. with external DAC or Sr.



Example: QD (command)
 D0:213 D1:6E4 (reply)
 The analog outputs are currently set for 0.648 V and 2.153 V.

Example: QF (command)
 F:15B4 (reply)
 A frequency of 20.1 Hz is being applied to DIO0.

QE Query everything

Returns the status of the digital inputs and outputs and analog inputs and outputs. Module configuration, frequency input, and Touch Memory must be queried individually. Only the I/O for which the module is configured is returned, so it is important to look at the leading labels on each value to determine what it represents.

Syntax: QE
i o a0 a1 d0 d1 (Answer MAN Sr.)
i o a0 a1 a2 a3 (Answer MAN Jr.)
i o (No analog)

where: *i* = digital inputs
o = digital outputs
a0–a3 = analog inputs
d0, d1 = analog outputs

Hardware: Answer MAN Jr. or Sr.

Example: QE (command)
 I:E6 O:47 A4:7E2 A5:931 D0:A78 D1:02B (reply)
 The Answer MAN Sr. digital inputs are currently at E6, the outputs are set for 47, the analog inputs are at 2.463 V and 2.872 V, and the analog outputs are set for 3.271 V and 0.052 V.

QF Query frequency input

A square wave with a frequency in the range of 2 Hz–2 kHz may be read on the DIO0 input. The value returned is a 16-bit hexadecimal value representing the period of the signal. To convert to a frequency, use the following:

$$\text{Frequency} = \frac{1}{\text{Period} \times 8.941 \times 10^{-6}}$$

Syntax: QF
word

where: *word* = 4-digit hex period value

Hardware: Answer MAN Jr. or Sr.

QI Query digital inputs

The eight digital inputs (DIO0–7) are read and returned as a single 8-bit hexadecimal value. Any port bits configured as outputs return their current settings.

Syntax: QI
n

where: *n* = 2-digit hex byte representing digital inputs

Hardware: Answer MAN Jr. or Sr.

Example: QI (command)
 I:4A (reply)
 Bits 1, 3, and 6 of the input port are set while the rest are clear.

QM Query current, average, max, and min analog inputs

Read the analog inputs and return the current value, average value of last eight readings, maximum value, and minimum value. The min and max values are reset after being read if the module is configured to do so (bit 5 in the configuration word). Otherwise, they must be cleared manually using the RM command.

Min, max, and average values are retained only for the two 12-bit analog channels.

Syntax: QM
cur0 avg0 max0 min0 cur1 avg1 max1 min1

where: *cur0, cur1* = current analog input values
avg0, avg1 = average of last eight readings
max0, max1 = maximum values obtained
min0, min1 = minimum values obtained

Hardware: Answer MAN Jr. with external ADC or Sr.



Examples: QM (command)
A4:8D2 V:8D0 X:8D7 N:8C9 A5:275
V:278 X:26F N:27B (reply)
The current, average, max, and min values
for Answer MAN Sr. 12-bit analog channels.

QO Query digital outputs

The current settings of the eight digital outputs (DIO0–7) are returned as a single 8-bit hexadecimal value.

Syntax: QO (command)
n
where: *n* = 2-digit hex byte representing
digital outputs
Hardware: Answer MAN Jr. or Sr.
Example: QO (command)
O:72 (reply)
Bits 1, 4, 5, and 6 of the output port are set
while the rest are clear.

QP Query printer error status

If an error occurs when the Answer MAN is trying to print, the module has no option but to abort printing and throw away the text string it was trying to print. The QP command may be used to find out if such an error occurred during the last S= command. A 00 is returned if there was no error, and FF is returned if there was an error.

Syntax: QP (command)
n
where: *n* = 00 for no error, FF for error on
last print
Hardware: Answer MAN Jr. or Sr.
Example: QP (command)
P:FF (reply)
An error occurred while trying to print.

QS Query Touch Memory serial number

When a Touch Memory device is touched to the reader, Answer MAN reads the serial number from the device and saves it. QS returns the last read serial number. If multiple devices are read between queries, only the last

is retained. All zeros are returned if nothing new has been read since the last query.

Syntax: QS (command)
t0 t1 t2 t3 t4 t5 t6 t7
where: *t0–t7* = 2-digit hex bytes returned by
Touch Memory device
Hardware: Answer MAN Jr. or Sr. with a
Touch Memory circuit
Example: QS (command)
S:02 46 F2 00 00 00 00 98 (reply)
A DS1991 with a family code of 02, a serial
number of 00000000F246, and a CRC of 98
has been read since the last query.

QT Query totalizer count

The totalizer keeps a running count of the number of pulses that have been received on the DIO0 input. It is triggered on the rising edge at approximately a 2v threshold. The counter can be queried at any time using the QT command. The value returned is a 24-bit hexadecimal value representing the number of pulses received since the last time the totalizer was cleared. The RT command must be used to clear the count.

Syntax: QT (command)
word
where: *word* = 6-digit hex period value
Hardware: Answer MAN Jr. or Sr.
Example: QT (command)
T:01B726 (reply)
A total of 112,422 pulses have been detected
on DIO0 since the last time the counter was
cleared.

RE Reset (clear) EEPROM contents

The EEPROM in the Answer MAN saves various parameters while the module's power is off. Such parameters include module configuration, operational mode baud rate, module name, I/O port bit directions, and reply delay. RE clears the EEPROM so the module uses all its defaults and restarts the module to force those defaults to take effect immediately. Note that if the CFG pin is floating when the RE command is issued, the module comes up in operational mode.



This command only works when the module is in configuration mode.

Syntax: RE

Hardware: Answer MAN Jr. or Sr.

Example: RE
Clear the EEPROM and restart the module.

RM Reset analog in min/max storage

In normal operation, the minimum and maximum values stored for the 12-bit analog inputs are retained indefinitely (unless the module is configured to clear them when they are read). RM clears the min and max values on receipt.

Syntax: RM

Hardware: Answer MAN Jr. with external ADC or Sr.

Example: RM
Clear the min and max values.

RT Reset the totalizer count

When enabled, the totalizer continues counting incoming pulses even after the totalizer has been read, eventually rolling over after FFFFFFF. RT clears the totalizer count.

Syntax: RT

Hardware: Answer MAN Jr. or Sr.

Example: RT
Clear the totalizer count.

S= Print text string

Display the text string on a parallel printer (if the module is configured for printer output). The module contains a 32-character buffer for the incoming message but is limited by the speed of the printer. You should avoid sending large numbers of long messages unless you provide sufficient time between transmissions.

There is no way to find out if the Answer MAN is busy printing, but the QP command may be used to find out if an error occurred when trying to print.

This command is compatible with the original HCS LCD-Link S= command.

Syntax: S=*string*

where: *string* = any alphanumeric text string up to 32 characters long

Hardware: Answer MAN Jr. or Sr. with printer circuitry

Example: S=This is a test\n
The given text string is displayed on the printer and the cursor is left at the beginning of the next line.

SB Set the I/O port bit directions

Answer MAN's eight digital I/O lines may be configured for either input or output on a bit-by-bit basis. An 8-bit hexadecimal value determines the bit directions. Putting a 1 in a bit position sets the corresponding I/O bit for input. A 0 sets the bit for output. Bit directions may be changed at any time.

Syntax: SB *n*

where: *n* = hex byte with new I/O port bit directions (00–FF)

Hardware: Answer MAN Jr. or Sr.

Example: SB C3
Set bits 0, 1, 6, and 7 for input, and the rest for output.

SBD Set the default I/O port bit directions

When the Answer MAN's power is turned off, the bit directions set using the SB command are lost. In order to have the Answer MAN set the bit directions to default values at powerup, the SBD command must be used to store default directions in EEPROM. See the SB command for more details about bit directions.

Syntax: SBD *n*

where: *n* = hex byte with new I/O port bit directions (00–FF)

Hardware: Answer MAN Jr. or Sr.

Example: SBD 5A
At powerup, bits 1, 3, 4, and 6 are set for input, and the rest for output.

SD Set DACs (analog outputs)

Answer MAN Sr. supports two 12-bit digital-to-analog converters. Any 12-bit hexadecimal value (000–FFF) may be set on each DAC. Both must be set at the same time.

Syntax: SD *n0 n1*

where: *n0, n1* = 12-bit values for AOUT0 and AOUT1 (000–FFF)

Hardware: Answer MAN Jr. with external DAC or Sr.

Example: SD 8C2 182
Set AOUT0 to 2.737 V and AOUT1 to 0.471 V.

SL Set analog threshold limits

Answer MAN can monitor its analog inputs and set or clear corresponding digital outputs when high or low thresholds are reached. SL is used to set the high and low limits for a specific channel. Each analog channel must be set individually.

Syntax: SL *ch lo hi*

where: *ch* = analog channel to set (0–5)
lo = low threshold value (0000–FFFD)
hi = high threshold value (0001–FFFE)
hi must be greater than *lo*

Hardware: Answer MAN Jr. or Sr.

Example: SL 2 4F F0
The 8-bit analog channel 2 is monitored by Answer MAN. Output bit 2 is set when the analog conversion value is less than 4F or greater than F0. The bit is cleared when it's inside the range.

SLD Set default analog threshold limits

When the Answer MAN's power is turned off, any analog limits set using the SL command are lost. In order to have

the Answer MAN respond to analog readings immediately at powerup, the SLD command must be used to store a default set of limits in EEPROM. See the SL command for more details about the limits.

Syntax: SLD *ch lo hi*

where: *ch* = analog channel to set (0–5)
lo = low threshold value (0000–FFFD)
hi = high threshold value (0001–FFFE)
hi must be greater than *lo*

Hardware: Answer MAN Jr. or Sr.

Example: SLD 5 3F0 600
The 12-bit analog channel 5 is monitored by Answer MAN. Output bit 6 is set when the analog conversion value is less than 3F0. Output bit 7 is set when the value is greater than 600. Both bits are cleared when the conversion is inside the range.

SO Set the digital outputs

The eight digital outputs (DIO0–7) are set to the given hexadecimal value. Any port bits configured as inputs are unaffected by this command.

Syntax: SO *n*

where: *n* = hex byte with new values for outputs (00–FF)

Hardware: Answer MAN Jr. or Sr.

Example: SO C3
Set bits 0, 1, 6, and 7 high, and the rest low.

SP Set PWM output parameters

When enabled with the CO command, SP causes the PWM output (AIN3) to become active and generate a waveform with the given total period and high period. Convert between period, frequency, and duty cycle using the equations below. Approximate range is 2 Hz–3.5 kHz, 5–95% duty cycle.

Syntax: SP *tp hp*

where: *tp* = total period count (0020–7FFF)



hp = high period count (0008–7FF0)
 tp must be greater than hp

$$tp = \frac{1}{\text{Frequency} \times 8.94 \times 10^{-6}} \quad hp = \text{Duty Cycle} \times tp$$

$$\text{Frequency} = \frac{1}{tp \times 8.94 \times 10^{-6}} \quad \text{Duty Cycle} = \frac{hp}{tp}$$

Hardware: Answer MAN Jr. or Sr.

Example: SP 2000 800
 Start a PWM waveform with a frequency of 13.64 Hz with a 25% duty cycle.

SPD Set default PWM parameters

When the Answer MAN's power is turned off, any PWM parameters set using the SP command are lost. In order to have the Answer MAN start a PWM waveform immediately at powerup, the SPD command must be used to store a default set of PWM parameters in EEPROM. See the SP command for more details about the parameters.

Syntax: SPD tp hp

where: tp = total period count (0010–7FFF)
 hp = high period count (0008–7FF0)
 tp must be greater than hp

Hardware: Answer MAN Jr. or Sr.

Example: SPD 2000 800
 Store the parameters for a PWM waveform with a frequency of 13.64 Hz with a 25% duty cycle in EEPROM.

ST Set totalizer debounce period

When totaling incoming pulses, the signal edges can be quite ragged if something like a switch is producing them. The result would be several counts of every edge if the input wasn't debounced. A debounce period of up to 255 ms may be set to clean up those ragged edges. Note that the longer the period, the lower the effective frequency that can be handled on the input.

Syntax: ST n

where: n = number of milliseconds of debounce delay
 (00–FF, in hexadecimal)

Hardware: Answer MAN Jr. or Sr.

Example: ST 38
 Set Answer MAN to use a 56-ms debounce period.

7.0 COMPATIBLE FEATURES

While the Answer MAN supports many different features, not all those features may be used simultaneously. The module has limited resources and in many cases uses a single pin for more than one function.

When issuing the CO (configure options) command, you're free to specify any or all options. However, the module is smart enough not to allow you to enable two mutually exclusive functions. When in doubt, configure the module as you want it, then read the configuration back using the QC (query configuration) command. The result is the actual module configuration.

Both Answer MAN Jr. and Sr. are capable of supporting the same features. They differ only in what hardware is included in the module.

The table in Figure 7.1 shows which functions may be used concurrently. When concurrent use is shown as restricted, you may use some of the features in the row concurrently, but not all of them. For example, when

You may also use...

		Digital I/O	12-bit analog I/O	8-bit analog in	*Analog limits	PWM out	Frequency in	Totalizer in	Printer out	Touch Memory
12-bit analog I/O	X	-	X						X	X
8-bit analog in	X	X	-	X						
*Analog limits	X	X	X	-						X
PWM out	X				-				X	
Frequency in	X					-				
Totalizer in	X						-			
Printer out		X							-	X
Touch Memory	X	X		X					X	-
KeyPad/LCD		X								

X = concurrent use always allowed
 X = concurrent use restricted

Figure 7.1: Answer MAN restricts which features may be used concurrently.

*Note: When using 8 bit analog limits, upper nibble of digital I/O is accessible. When using 12 bit analog limits, lower nibble of digital I/O is accessible.



printer output is the feature you're primarily interested in, you may use 12-bit analog inputs without restriction, but you must select between PWM and Touch Memory. Both can't be used at the same time.

When in doubt, use the CO command to set the configuration word, then use the QC command to read

back the configuration and see what feature combination the Answer MAN allowed.

8.0 DIGITAL I/O

Both Answer MAN Jr. and Sr. support eight digital I/O lines. The direction of each bit can be individually selected using the SB command and may be changed at any time.

8.1 HARDWARE

The digital I/O lines are TTL compatible, so the user must include buffers on the inputs and drivers on the outputs when interfacing to devices that require higher currents or voltages than a TTL line can handle. Damage caused by applying a high voltage to an input or drawing too much current from an output is **not** covered by warranty.

8.2 CONFIGURATION

Nothing special must be done to enable the digital I/O port.

8.3 SOFTWARE

The SO command sets the digital outputs, while the QI command reads the digital inputs. The QO command may also be used to read back the current setting of the output bits. All eight bits of the I/O port must be read or written at the same time.

The input bits may be read at any time, and the output bits may be written at any time. However, when using features that use the I/O port pins (such as PWM generation), reading or writing the ports directly may interfere with those special features. See Section 7 for more details about when the digital I/O port may be used concurrently with other features.

9.0 ANALOG I/O

Both Answer MAN Jr. and Sr. support four 8-bit analog inputs. Answer MAN Sr. also supports two 12-bit analog inputs and two 12-bit analog outputs. With the addition of external components, Answer MAN Jr. can also support 12-bit analog I/O.

9.1 HARDWARE

The 8- and 12-bit analog inputs all accept voltages in the range of 0–5 V. A smaller range may be used, but you give up some resolution by not scaling the signal to use the full 0–5-V range supported by the module. Take care not to exceed 5 V on any analog input. Damage caused by applying a high voltage to an input is **not** covered by warranty.

The 12-bit analog outputs produce a voltage in the range of 0–5 V. Be sure to use a buffer between the Answer MAN and the device being controlled if that device needs more current than the Answer MAN can provide. Damage caused by drawing too much current from an output is **not** covered by warranty.

9.2 CONFIGURATION

Set bit 0 in the configuration word (using the CO command) to enable 12-bit analog I/O. Set bit 1 in the configuration word to enable 8-bit analog input. If no analog is to be used at all, both bits 0 and 1 may be cleared.



9.3 SOFTWARE

The SD command is used to set the analog outputs, while the QA command is used to read the analog inputs. The QD command may also be used to read back the current setting of the outputs.

For the 12-bit analog I/O, values consist of 12-bit hexadecimal numbers represented as three hex digits. For 8-bit analog inputs, two hex digits are used to represent 8-bit numbers. When fewer than three (or two) digits are specified, leading zeros are assumed.

10.0 ANALOG INPUT THRESHOLDS

Answer MAN may be set up to automatically monitor any of the analog inputs and set corresponding digital outputs when a high or low limit has been exceeded. Using this feature, the Answer MAN can exercise limited autonomy by not requiring the services of a central computer to react to local conditions.

10.1 HARDWARE

See Section 9.1 for details on analog-input hardware requirements.

10.2 CONFIGURATION

Set bit 6 in the configuration word (using the CO command) to enable 12-bit analog input limit checking. Set bit 7 in the configuration word to enable 8-bit analog checking. If no limit checking is to be used, both bits 6 and 7 may be cleared.

When 8-bit checking is enabled, DIO0–3 are automatically configured as outputs and will change in response to values on analog inputs AIN0–3. When 12-bit checking is enabled, DIO4–7 are configured as outputs and change in response to AIN4 and AIN5.

10.3 SOFTWARE

The SL command sets the high and low limits for individual channels. The SLD command may be used to store the limits in EEPROM for use at powerup or reset.

Figure 10.1 illustrates the behavior of the digital output bits in response to analog inputs. For 8-bit analog inputs, the corresponding digital output bit is set whenever the analog conversion value is less than the lower limit or greater than the upper limit. The output is cleared when the value is between the limits.

For 12-bit analog inputs, separate bits are set when the high and low limits are exceeded.

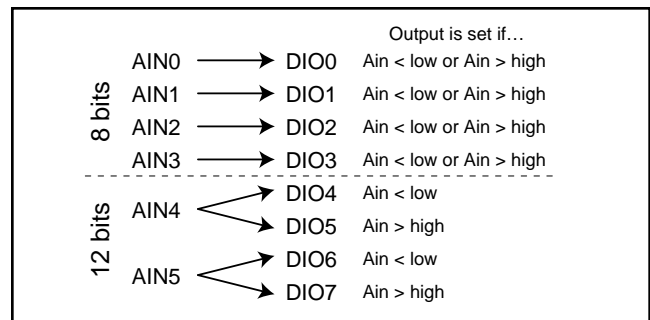

Figure 10.1: Analog input threshold behavior.

11.0 PWM OUTPUT

The Answer MAN can be used to generate a variable-frequency, variable-duty-cycle square wave, often called a pulse-width modulated waveform. By specifying the total waveform period and the duration of the high portion of the period, any frequency from 2 Hz to 3.5 kHz with a duty cycle of 5–95% may be synthesized.

11.1 HARDWARE

The PWM waveform comes from the AIN3/PWM line (pin 8). No additional circuitry is required.

11.2 CONFIGURATION

To enable the PWM output, set bit 2 of the configuration word (using the CO command). Until waveform parameters have been set (see Section 11.3), the PWM output remains idle, even after being enabled.

11.3 SOFTWARE

To specify the waveform parameters, use the SP command to set the total and high period values. See the SP command in Section 6 for more details.



The parameters set using the SP command only stay in effect until power is removed from the Answer MAN. When power is reapplied, the PWM output remains idle, even if it's enabled in the configuration word. Use the

SPD command to store a set of default parameters in EEPROM to be used on powerup. See the SPD command in Section 5 for more details.

12.0 FREQUENCY INPUT

Answer MAN can be used to measure the frequency of a square wave applied to one of its input pins. Any frequency from 2 Hz to 2 kHz may be measured.

12.1 HARDWARE

The waveform should be applied to the DIO0 line (pin 17). All other digital I/O lines remain available. No other circuitry is required.

12.2 CONFIGURATION

The frequency input feature is enabled by setting bit 3 of the configuration word (using the CO command).

12.3 SOFTWARE

The QF command is used to query the current frequency input measurement. The value returned is actually the period of the waveform. See the QF command in Section 6 for more details.

13.0 TOTALIZER INPUT

Rather than measuring the time between pulses as is done with the frequency feature, the totalizer feature can be used to count the number of pulses received over a known time period. Up to 2^{24} (16,777,216) pulses can be counted at rates up to 500 Hz.

13.1 HARDWARE

The waveform should be applied to the DIO0 line (pin 17). All other digital I/O lines remain available. No other circuitry is required.

13.2 CONFIGURATION

The totalizer input feature is enabled by setting bit 9 of the configuration word (using the CO command).

13.3 SOFTWARE

The QT command is used to query the current totalizer count. The count is *not* automatically cleared when read. Use the RT command to reset the count.

14.0 iBUTTONS (TOUCH MEMORY)

Dallas Semiconductor makes a line of small devices the size of button-cell batteries that can be used to hold data. Referred to as iButtons (formerly Touch Memory), every one of these devices contains a unique 48-bit serial number laser etched into its silicon. The Answer MAN can read the serial number from most members of the iButton family.

iButtons use a unique one-wire interface that makes inserting the device into a reader quick and foolproof. An

example application is a door-access controller. Every person authorized for entry into a particular area has an iButton device attached to their ID badge, on their keychain, or in a ring worn on their finger. To unlock the door, they press the iButton device into the reader mounted next to the door. The Answer MAN reads the device and reports the serial number back to the main computer. The computer looks up the number to find out who the person is and issues a command to the Answer



MAN to unlock the door if a match is found.

For more information on iButtons and the various devices available, contact Dallas Semiconductor, 4401 S. Beltwood Pkwy., Dallas, TX 75244-3292, and ask for the *Automatic Identification Data Book*.

14.1 HARDWARE

The Answer MAN's iButton interface requires the addition of just an iButton receptacle and a single pull-up resistor. Figure 14.1 shows the necessary connection.

14.2 CONFIGURATION

To enable the Touch Memory interface, set bit 8 in the configuration word (using the CO command).

14.3 SOFTWARE

The QS command retrieves the serial number read from the last iButton device since the last poll. If no device was read, all zeros are returned. The first byte returned is the device family code while the last byte is the CRC.

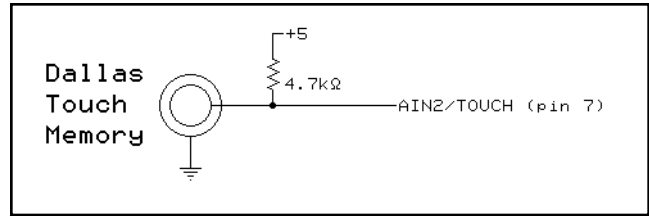

Figure 14.1: Interface circuitry necessary for adding iButton to the Answer MAN.

Specific members of the iButton family supported include: DS1990A, DS1991, DS1992, DS1993, DS1994, DS1995, DS1996, DS1982, DS1985, DS1986, and DS1920. Most newer devices are also supported. The original DS1990 is *not* supported.

Note that many of the above devices include features besides the serial number, such as RAM and temperature sensing. None of these additional features may be accessed using the Answer MAN.

15.0 PRINTER OUTPUT

In applications where a remote parallel printer could be useful, Answer MAN can be used to provide the network interface for such a printer. By making a few connections between the Answer MAN and a parallel printer, status messages may be printed by sending the Answer MAN commands over the twisted-pair network.

15.1 HARDWARE

Figure 15.1 shows the necessary connections between an Answer MAN and a printer with a standard Centronics interface. No other circuitry is required.

15.2 CONFIGURATION

Printer output is enabled by setting bit 4 of the configuration word (using the CO command).

15.3 SOFTWARE

The S= command sends text strings to the printer. Be very aware that the Answer MAN has a buffer of only 32

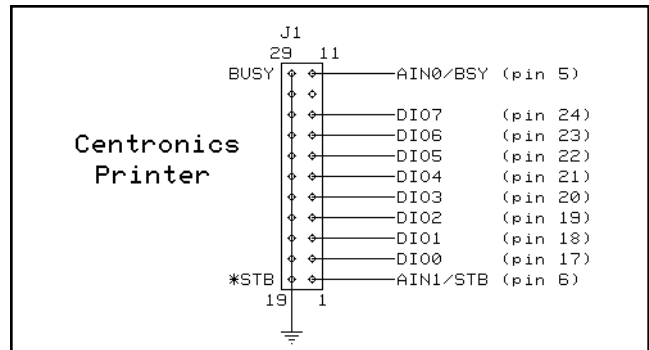

Figure 15.1: Answer MAN connections to a Centronics printer.

characters, and that printers vary in how long they take to accept characters from the Answer MAN. While Answer MAN is in the process of sending data to the printer, it is not available to respond to additional commands or polls. Be sure to leave sufficient time for the process to complete after initiating a print.

Sometimes problems arise in the communication between the Answer MAN and the printer, or an error

condition on the printer prevents the printing process from finishing. If the Answer MAN times out waiting for the printer, it throws away the remainder of its buffer. The QP command may be used to determine if such an error took place during the last print operation.

If an error is flagged, the S= command should be tried again. If the second attempt fails, the host computer can assume a problem with the printer and take appropriate action.

16.0 DEVELOPMENT BOARD

While the Answer MAN is intended to be used plugged into a user-developed board, it can also be used stand-alone by plugging it into the Answer MAN Development Board (AMDB). The AMDB includes a socket for the Answer MAN; jumper headers for the *RESET and *CFG signals; screw terminals and a DE9 connector for

the serial I/O; pin headers for the analog and digital I/O; and space to plug in serial level shifters, ADCs, and DACs to bring an Answer MAN Jr. up to the same functionality as an Answer MAN Sr.

Figure 16.1 shows the schematic for the AMDB. Figure 16.2 shows the silkscreen.

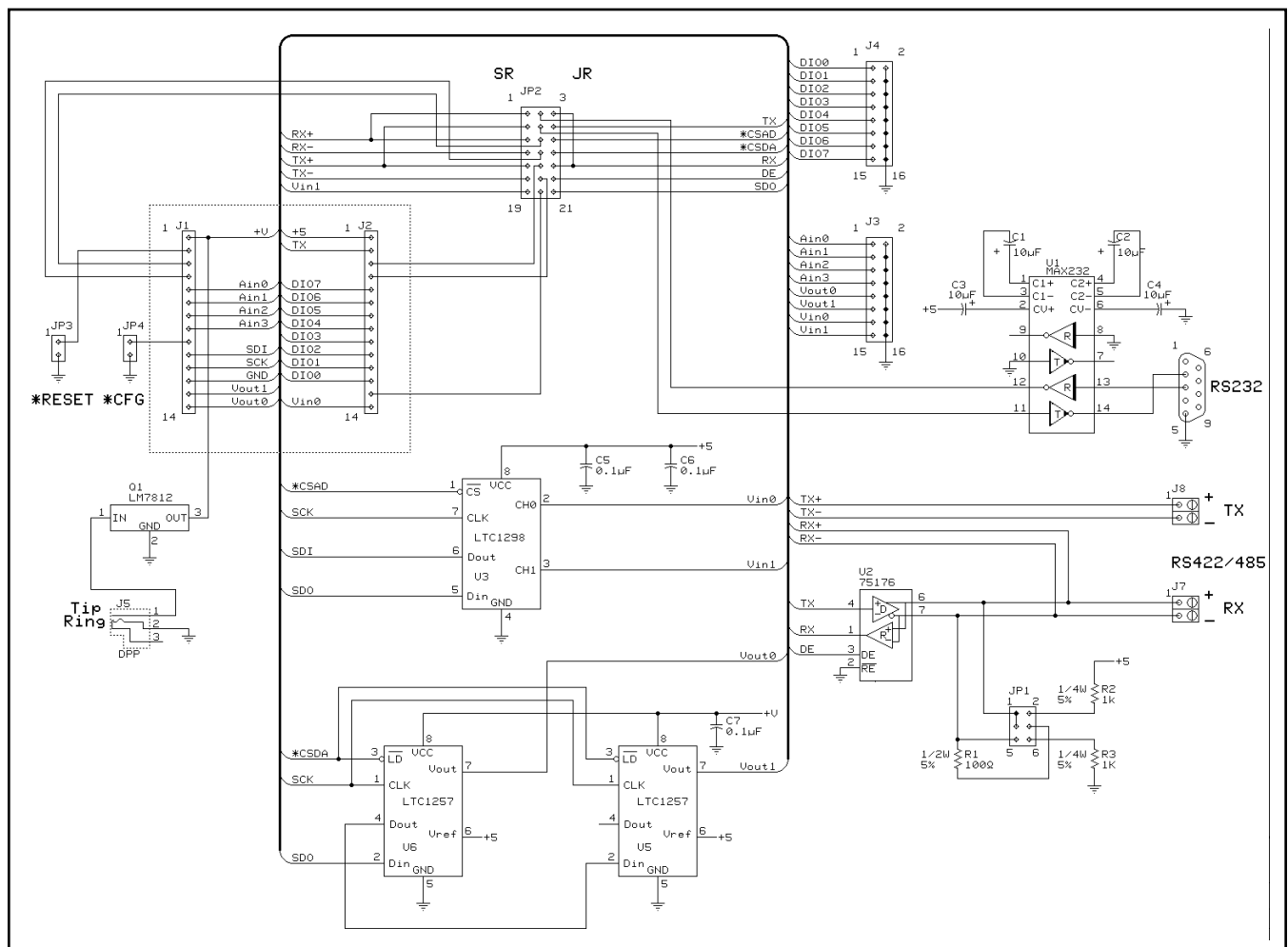

Figure 16.1: Answer MAN Development Board schematic.

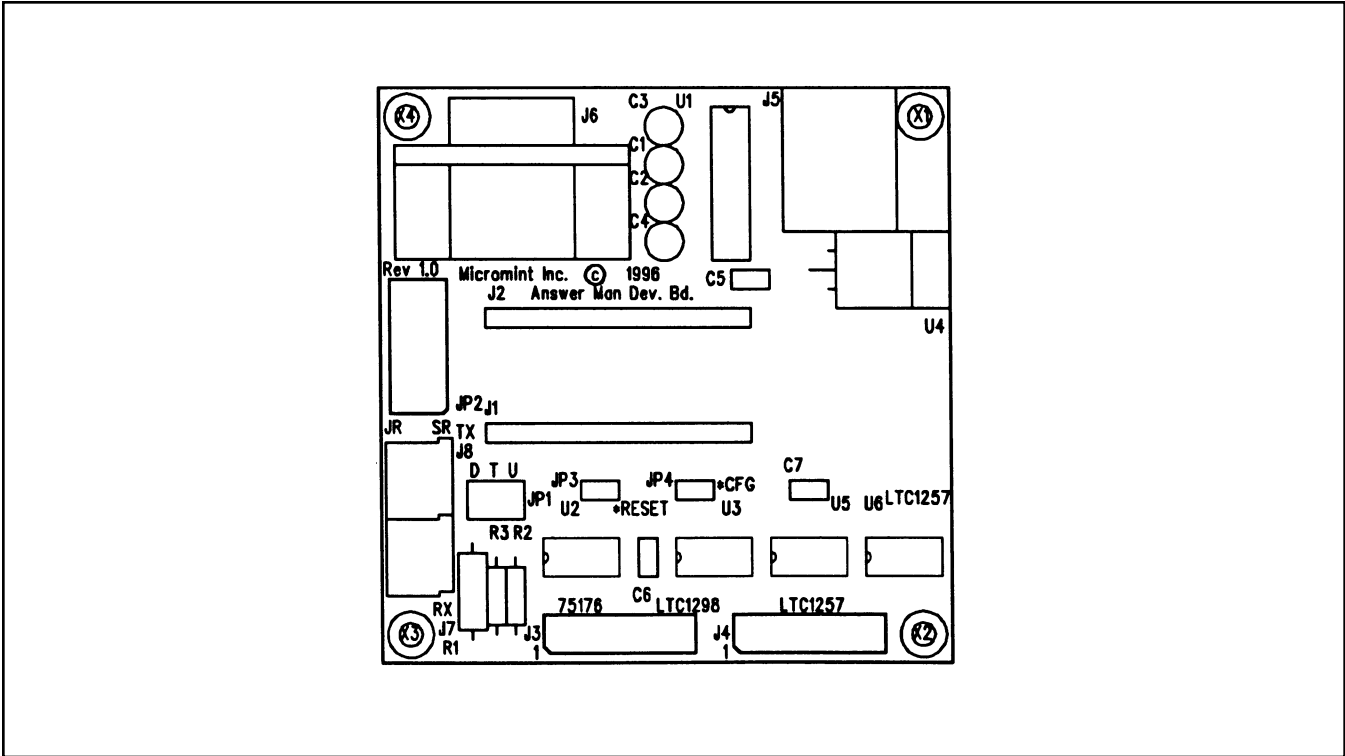

Figure 16.2: Answer MAN Development Board silkscreen.

Devices sold by Micromint are covered by the warranty and patent indemnification provisions appearing in its Terms of Sale only. Micromint makes no warranty, express, statutory, implied, or by description regarding the information set forth herein or regarding the freedom of the described devices from patent infringement. Micromint makes no warranty of merchantability or fitness for any purposes. Micromint reserves the right to discontinue production and change specifications and prices any time and without notice. This product is intended for use in normal commercial applications. Applications requiring extended temperature and unusual environmental requirements, or applications requiring high reliability, such as military, medical life support or life-sustaining equipment, are specifically **not** recommended without additional processing by Micromint for such application.

Micromint Chips

Micromint, Inc.
 902 Waterway Place
 Longwood, FL 32750
 (407) 262-0066
 Fax: (407) 262-0069
<http://www.micromint.com/>

Version 1.1 Addendum LCD/Keypad Support

Version 1.1 and later of both Answer MAN Jr. and Sr. support an optional LCD display and scanned keypad. This document contains information not found in the regular datasheet relating to the configuration and use of the new features.

1.0 NEW COMMAND SUMMARY

- Q** query the push buttons and keypad of an Answer MAN configured for LCD mode. Up to eight keypad presses are buffered between network/serial polls. All eight push buttons are buffered.
- S=*string*** display appended text string on LCD. The firmware incorporates a 48-character buffer for the incoming message, so long text strings must be sent in multiple packets.

2.0 NEW COMMAND DETAILS

Note that, unlike the rest of the Answer MAN query commands, the Q command does not include a leading character tag to indicate the kind of data being returned.

Q Query the push buttons and keypad

An Answer MAN configured for LCD mode supports a 4 × 6 keypad. The upper two rows of the keypad simulate individual button presses and are returned first as an 8-bit byte in hex format. The lower four rows are mapped to the standard 16 hex characters (0–9 and A–F) and are returned as a string. Up to eight keypad key presses are buffered between network/serial polls.

This command is compatible with the original HCS LCD-Link Q command.

- Syntax: **Q**
buttons keys
- where: *buttons* = 2-digit hex value representing 8 buttons
keys = up to 8 hex digits representing keypad presses
- Hardware: Answer MAN Jr. or Sr. with keypad circuit

Example: **Q** (command)
12 78B0 (reply)
Two of the upper row buttons were pressed and the 7, 8, B, and 0 keys were pressed, all since the last query.

S= Print text string

Display the text string on the LCD display (if the module is configured for LCD operation). The module contains a 32-character buffer for the incoming message, so long strings must be sent in multiple packets.

This command is compatible with the original HCS LCD-Link S= command.

- Syntax: **S=*string***
- where: *string* = any alphanumeric text string up to 32 characters long
- Hardware: Answer MAN Jr. or Sr. with either LCD circuitry or printer circuitry
- Example: **S=This is a test\n**
The given text string is displayed on the LCD display and the cursor is left at the beginning of the next line.



3.0 LCD/KEYPAD

With the addition of a small amount of hardware, Answer MAN may be used as an LCD/keypad controller. Messages sent to the Answer MAN are displayed on a 4 x 20 LCD display (optional backlight control is also available). Also, up to eight discrete push buttons and a 4 x 4 scanned keypad may be connected for sending user input to Answer MAN.

3.1 HARDWARE

The schematic shown in Figure 3.1 includes everything necessary for Answer MAN Jr. and Sr. to support all the features described above. Only those portions required need to be added. For example, if just an LCD display is needed, the keypad may be eliminated.

3.2 KEYPAD/PUSH BUTTONS

Answer MAN supports both individual push buttons and a 4 x 4 keypad. The status of the buttons and keypad can be obtained using the Q command (see Section 2.0 and Figure 3.2).

The Q command first returns a 2-digit hex value that represents which buttons have been pressed since the last query. The eight buttons are mapped to the eight bits of the returned value. For example, if buttons that represent bits 0,1 and 7 have been pressed, a value of 83 is returned. There is no way to know how many times each button has been pressed, only that it has been.

After the button value, the Q command returns a list of up to seven keypad presses from the lower 16 keys. Each press of a key is returned as a single hex character

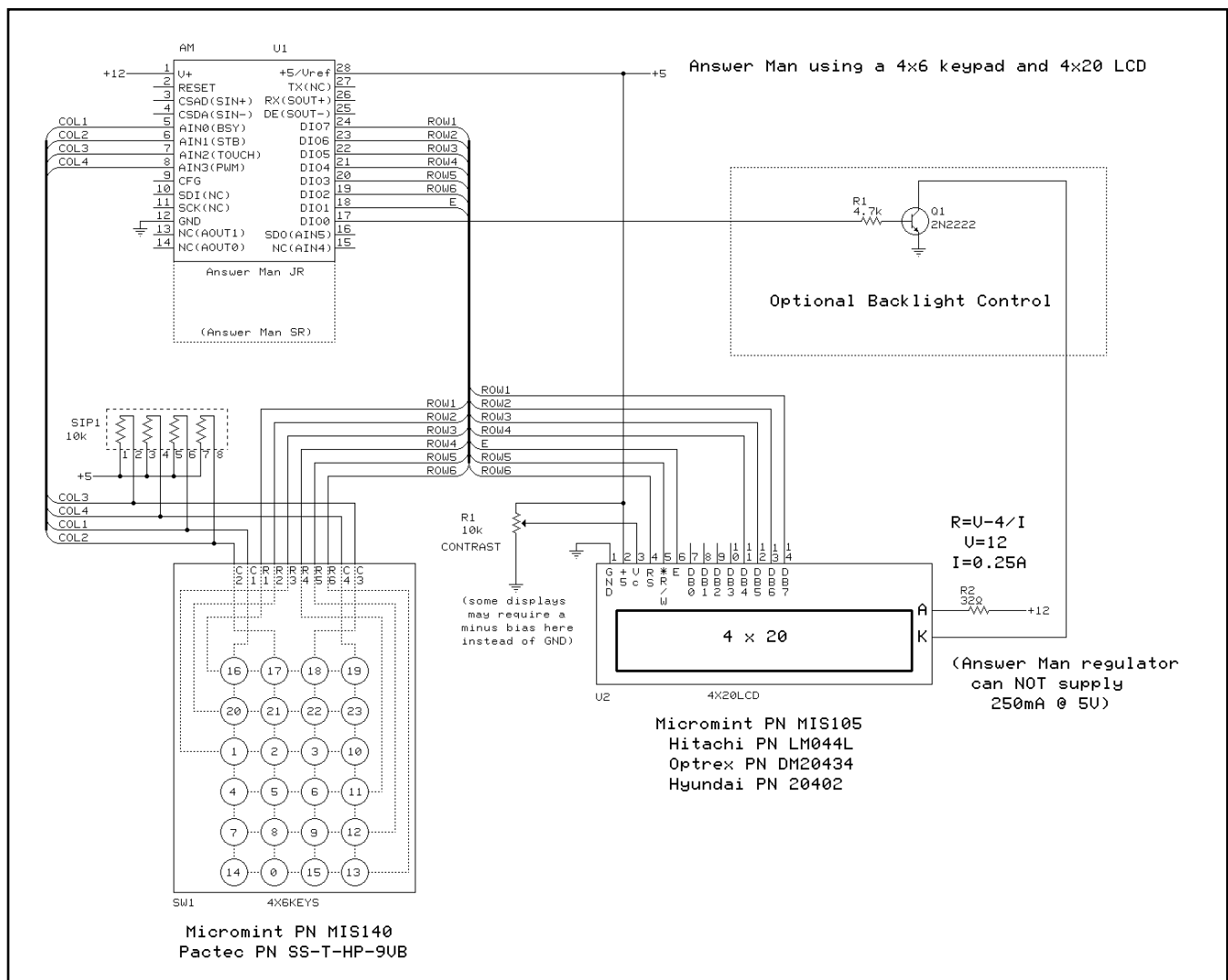

Figure 3.1: Interface circuitry necessary for adding an LCD display and keypad to the Answer MAN.

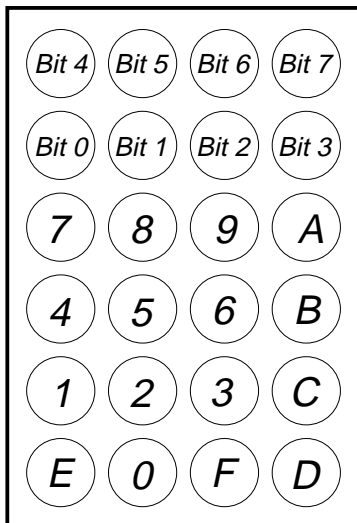

Figure 3.2: The Answer MAN button and keypad layout. The top eight buttons are returned by the Q command bitmapped into a single byte. The bottom 16 keys are returned by the Q command as the indicated ASCII characters.

0-F. Multiple presses of a key show up multiple times in the list. If more than seven keys are pressed between query commands only the first seven are buffered.

Each time a button or keypad key is pressed the LCD backlight is turned on for 16 seconds (if the backlight is under Answer MAN control).

3.3 CONFIGURATION

Bit 13 of the configuration word should be set (using the CO command) to enable LCD and keypad support.

3.4 SOFTWARE

The S= command interprets several C-style escape sequences to simplify sending “unprintable characters” in the ASCII string. All sequences start with a backslash (ASCII 5C) and are **case sensitive**.

- \b Bell (pulse bell signal line high for 0.5 s)
- \e Escape character, ASCII 27
- \f Formfeed character, ASCII 12
- \n New line (linefeed and carriage return)

- \r Carriage return (to current line, leftmost column)
- \xnn Send hex character nn (must have two digits)
- \\ Single backslash

The \x sequence is intended to display any character in the LCD controller’s character set including those above 0x7F. For example, the sequence \xDF displays a degree symbol.

3.5 ANSI CONTROL SEQUENCES

All control sequences begin with two characters:

- Esc—ASCII 27, the escape character (use \e)
- [—ASCII 91, the left square bracket

There are no blanks within the command strings. Numeric parameters are decimal and default to 1 if omitted. Row and column numbers start with 1. The upper/lower case of the trailing letter is important!

Note that the two cursor commands are not part of any official ANSI command set. Since no standard commands exist for turning the cursor on and off, two were defined for use with Answer MAN

Command	Example	
Esc[##;#H	Esc[H	Set cursor to row;col (to 1,1)
Esc[##;#f	Esc[1;2f	Set cursor to row;col (to 1,2)
Esc[##;#j	Esc[3j	Set cursor to row;col (to 3,1)
Esc[2J	Esc[2J	Clear display and home cursor
Esc[#h	Esc[7h	Set display mode (Esc[7h to wrap at end of rows)
Esc[#l	Esc[7l	Set display mode (that’s an “ell”; Esc[7l to force CR/LF at end of row)
Esc[b	Esc[b	Turn the cursor off
Esc[c	Esc[c	Turn the cursor on

Micromint Chips

Micromint, Inc.
902 Waterway Place
Longwood, FL 32750
(407) 262-0066
Fax: (407) 262-0069
<http://www.micromint.com/>

AnswerMAN Addendum

September 5, 1997

In some instances when using the AnswerMAN Jr. and the development board connected to a PC's RS-232 serial port, it is possible that the module will not reset or power-up correctly. Because the AnswerMAN requires such a small amount of power, a PC with a strong serial port is capable of providing enough power to the module so that it actually runs without the main power supply being connected. The problem shows itself as incomplete or incorrect sign-on messages and/or time-out errors when writing data to the EEPROM.

If you experience these symptoms, the problem can be corrected by either of the following methods:

1. Install a 470 Ω resistor between +5V and ground on the development board.
2. Disconnect the development board from the serial port before resetting it or powering it up.

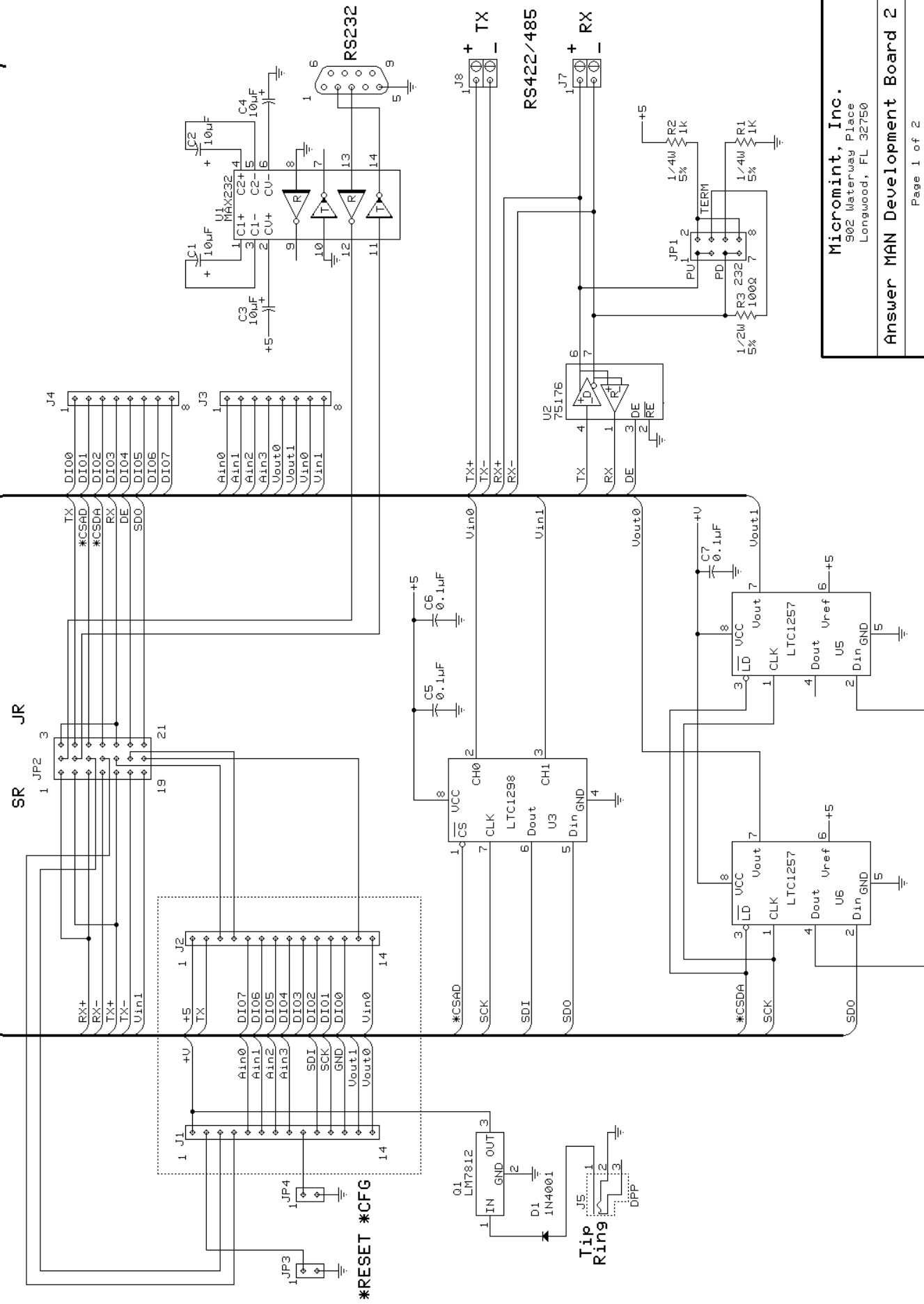

Micromint, Inc.
 902 Waterway Place
 Longwood, FL 32750

Option Bus

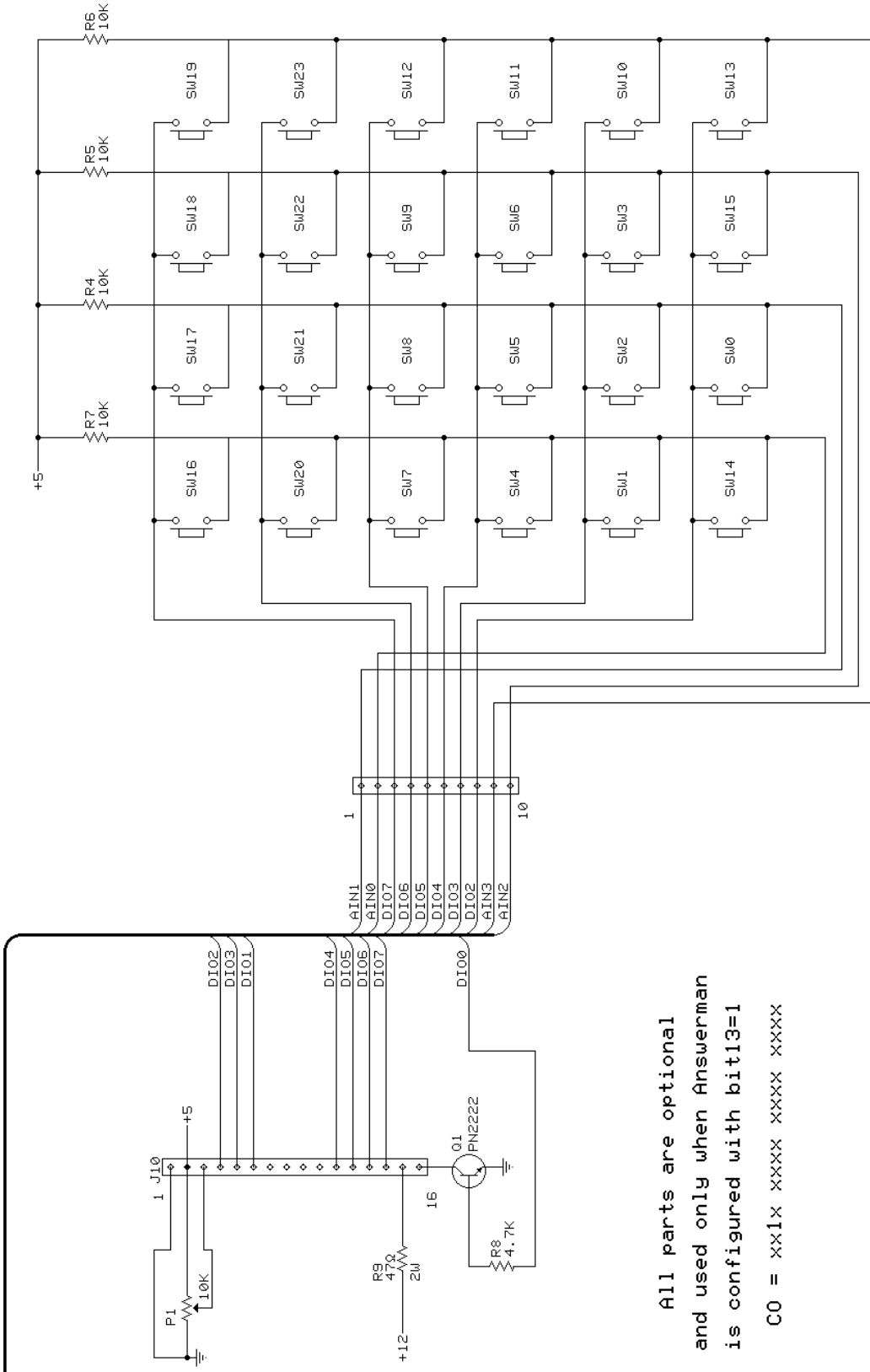

All parts are optional
 and used only when Answerman
 is configured with bit13=1
 C0 = xx1x xxxx xxxx xxxx

MICROMINT, INC.
 902 Waterway Place
 Longwood, FL 32750

Answer Man Development Bd. #2

Errata

9/4/98

Answer Man Dev. Brd. #2

Error on PC board does not allow Vin1 to be read

Please note that there is an error on version 1.0 of the Answer Man Dev. Brd. #2. A trace that connects Vin1 of U3 (LTC1298) to J3 is missing from the board. The simplest fix for this problem is to use an alternate connection point for Vin1. Instead of using hole #8 of J3, use the feed-thru near hole #4 of J3. The diagram below shows this more clearly.

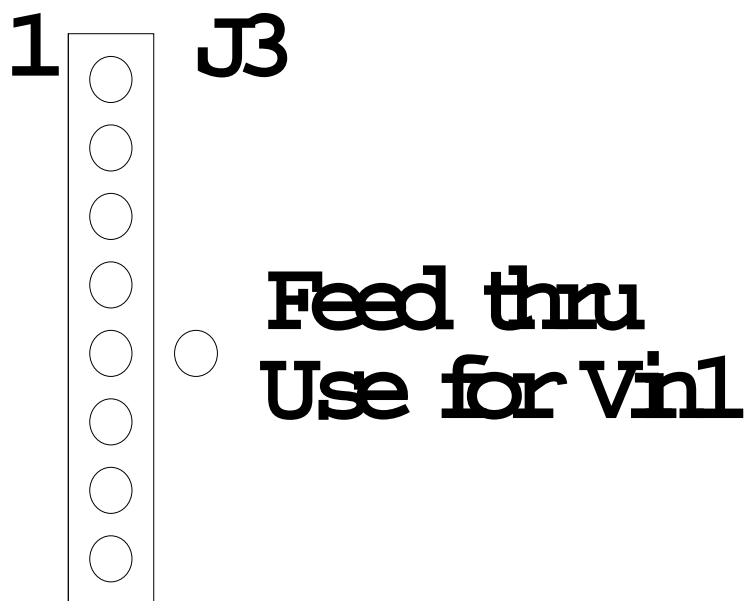

Since the feed-thru is covered by solder mask, you must carefully scrape the mask away before trying to solder a wire in place.